

Controlling the Polarized Emission of a Laser Generated Plasma

John Penczak, Robert Gordon, Yaoming Liu

Department of Chemistry, University of Illinois at Chicago, Chicago, IL, 60607

Introduction

Laser excitation of a plasma is a fertile ground for coherent control. Evidence for this is seen in the laser-induced breakdown spectroscopy (LIBS) of materials. A typical LIBS spectrum consists of discrete lines embedded in a broad continuum. The discrete lines are caused by resonant transitions of atoms and ions while the continuum is produced by plasma emission. The continuous emission has many of the hallmarks of a coherent mechanism that lends itself to control. These effects include nearly complete polarization at short wavelengths, quantitative correlation of the fluorescence polarization vector with the electric field of the laser, strong directionality of the emission, and a short lifetime. In this poster we present the results of a systematic study of the fs-LIBS spectrum of Al that demonstrate all of these properties.

Experimental Setup

We use a linearly polarized, 800 nm, ~50 femtosecond pulse from a Ti:Sapphire laser incident on an Al target with a pulse energy of 10-50 microjoules. We record the spectrum of a laser-generated plasma for various experimental parameters.

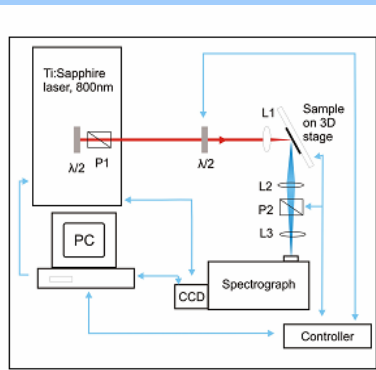

Fig. 1 Diagram of fs-LIBS setup, with polarizers P1 and P2, lenses L1 ($f=150$ mm), L2 (50 mm) and L3 (75mm), and half wave plates, $\lambda/2$.

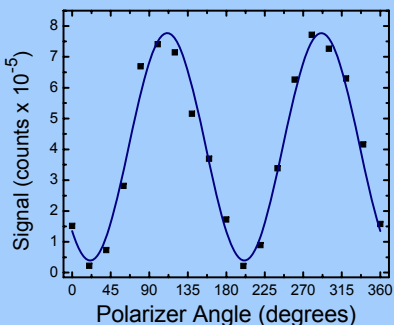

Fig. 2 Intensity of the spectral signal at 274 nm vs. orientation of the polarizer, fit to a Malus law function.

Results

From the Malus law fit we found polarization of the continuum emission > 95% for short wavelengths. We were also able to determine the angle of the polarization vector. We found that the polarization vector of the plasma was strongly correlated with polarization of the incident laser.

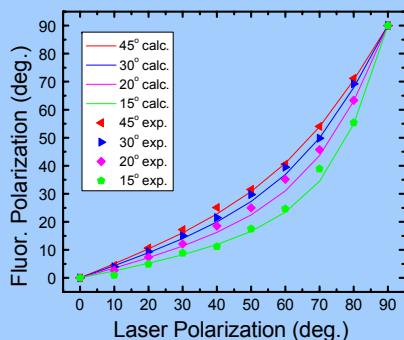

Fig. 3 Fluorescence polarization angle as a function of the incident laser polarization shown at different angles of incidence.

We realized that the fluorescence polarization vector was actually a geometric projection of laser polarization onto the plane of the detector. The curves shown in Fig. 3 represent the calculated values using the projection formula,

$$\tan\theta = \tan\Phi \cos\alpha \cos(\alpha - \beta)$$

θ = angle of fluorescence polarization in detector frame

Φ = angle of laser polarization in laser frame

α = angle of incidence relative to surface normal

β = angle between laser and detector

Our explanation of the correlation is that the laser creates a plasma on the surface of the material. This plasma interacts with the laser pulse and oscillates like a dipole parallel to the surface. This dipole then radiates out, projecting its polarization onto the detector. Our geometric projection formula predicts that the polarization should be dependent on the angle of incidence as well as the angle of detection, which was confirmed in a secondary experiment (Fig. 4).

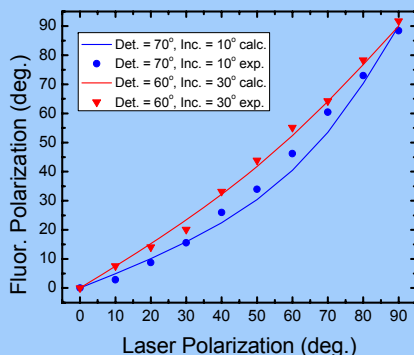

Fig. 4 Fluorescence polarization angle as a function of laser polarization at a fixed angle of incidence of 30 degrees at two different angles of detection.

It was also determined that the emission was highly directional, centered at the specular angle. A series of experiments were done varying the detector angle while keeping the angle of incidence constant, effectively scanning through angular distribution of the emission (Fig. 5).

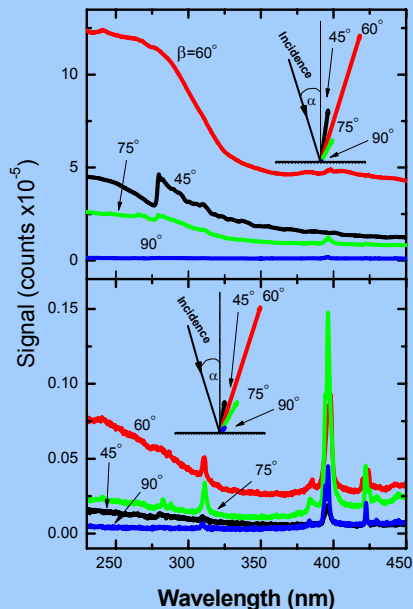

Fig. 5 Spectra taken at varying angles of detection (angle of incidence = 30 degrees) with the polarizer aligned with (top) and perpendicular to (bottom) the fluorescence polarization vector.

We expected that a highly polarized emission would have a short lifetime, because we believe that the laser pulse determines the polarization of the emission. When we were measured the lifetime of the emission we were surprised to find that continuum emissions, although short-lived relative to discrete emissions, still existed a few nanoseconds after the end of the laser pulse (Fig. 6).

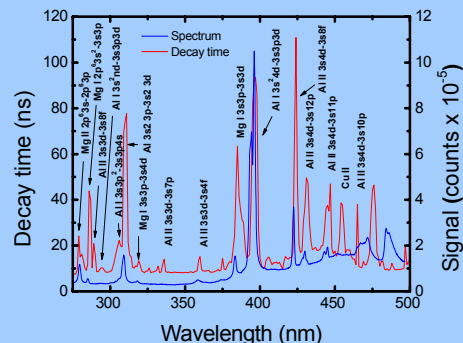

Fig. 6 Lifetime plot compared to regular LIBS spectra shows the lifetime peaks which could not be resolved with the LIBS measurement.

To further investigate the mechanism of the polarized emission, we split the pulse into two identical pulses. The pulses were temporally separated by ~1-100 picoseconds. We then analyzed the angle and the amount of polarization (Figs. 7 & 8).

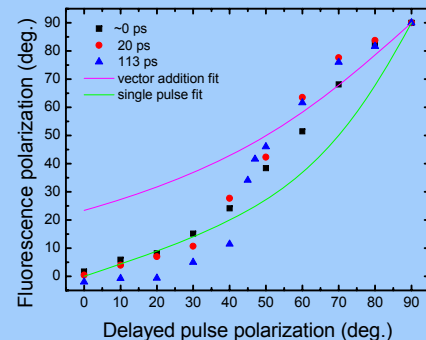

Fig. 7 Fluorescence polarization angle vs. laser polarization. The first pulse is fixed with p-polarization (90 degrees), while the polarization of the second pulse varies from s to p. The purple curve assumes that the two polarizations add vectorially, while the green curve shows the dependence as if only the second pulse were present.

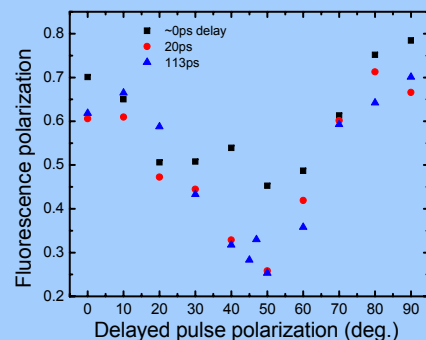

Fig. 8 Polarization of continuum emission for the same conditions as in the previous figure.

This shows a complex picture of two pulses interacting with the plasma. More work needs to be done to elucidate the mechanism and control of the polarized plasma emission.

Future Directions

In order to better explain the phenomena of controlling the electric field of the emission from a laser generated plasma we plan to...

- perform experiments in vacuum
- measure ion and photoelectron energy distributions
- improve the lifetime measurements
- use two pulses incident at different directions, phases, and polarization angles